

BAR MERCHANDISERS

WONDERBAR® SQUARE BAR MERCHANDISER

TRION® WONDERBAR® MERCHANDISERS

- Multi-purpose for use in coolers, freezers, candy aisle, center store, auto and more.
- Organizes department, enhances shopability.
- Mounts anywhere with Universal Brackets.
- Interchangeable with other bar systems.
- Adds both facings and rows to a display.
- Billboards items, increases sales up to 20%.
- Automatically feeds and faces product.
- Return on investment in as little as 90 days.
- Reduces labor 7-10 hours/week/8-foot section.
- System lifts out for easy rear stocking.
- Insures stock rotation; reduces spoilage.
- 48 facing resets in as little as 15 minutes.

For Freezers, Coolers, Dry Goods, Automotive, and Center Store 

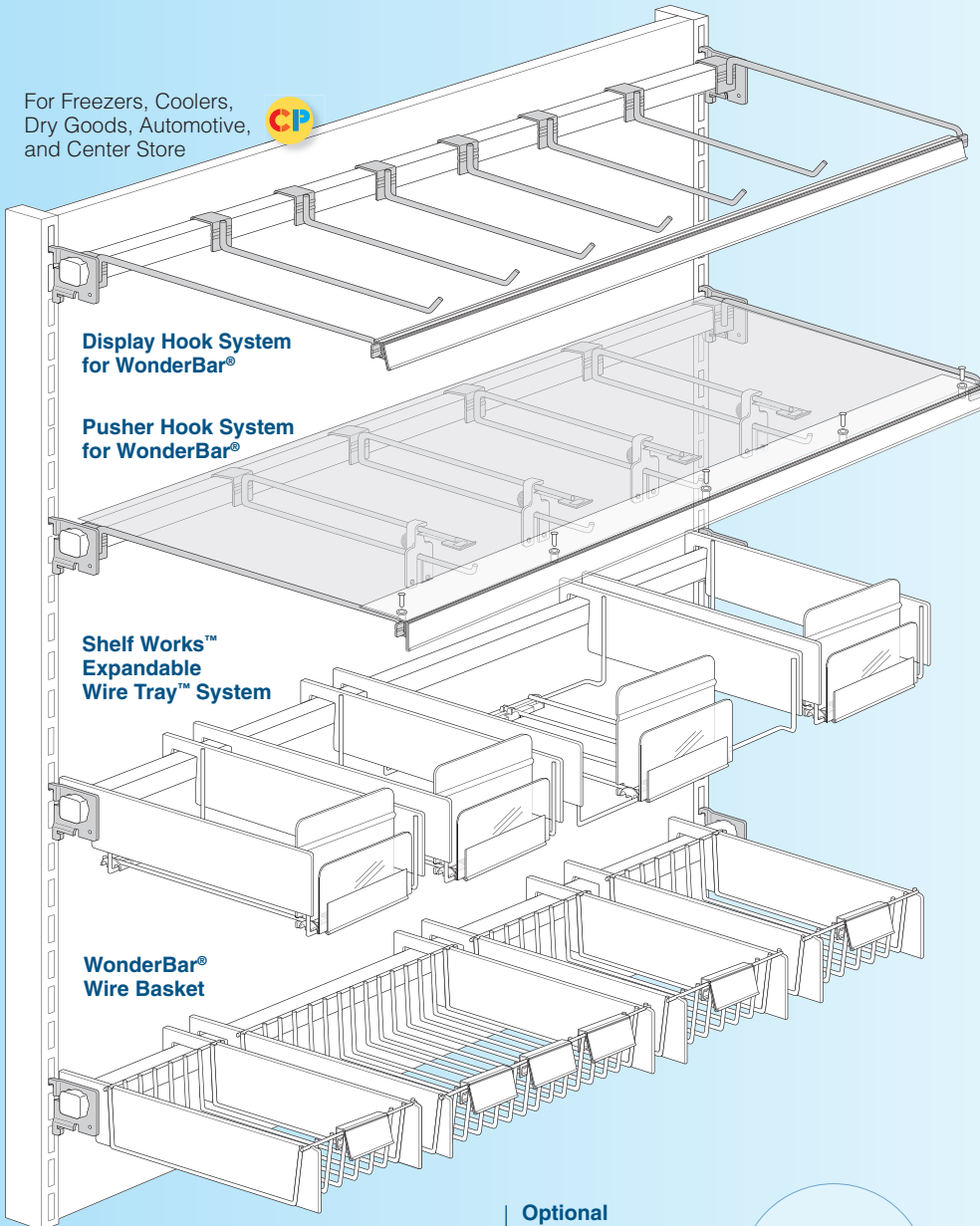

Patents and Patents Pending

Optional WonderBar™ Plus
Accepts plug-in style hooks in a variety of lengths.

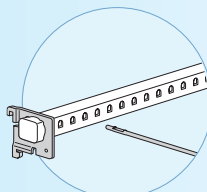

Simple, No Tools Installation

Fits all types of gondola upright including both thick- and thin-walled gondola uprights.

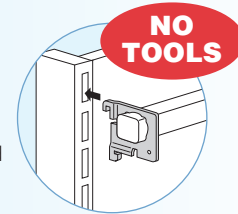

Square Bar

Less expensive than traditional rectangular bar, yet carries the same load.

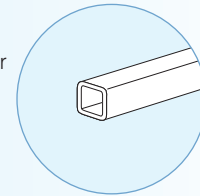

Clear Scan® AdjustaView® Label System

AdjustaView® available to run across the front of the display. Can be angled at -15°, 0°, or +15° to vertical. A range of label holder sizes are available to satisfy any labeling need.

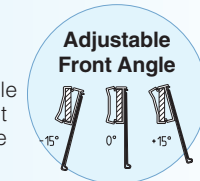

Air Flow Baffle

The Air Flow Baffle is used in open coolers to direct cold air to the front of the cabinet where product temperatures can be troublesome. May be used only with WonderBar® and pusher hooks. Works with 30mm and 39mm DBR label holders. Available in 48" width for use with 12", 14" and 16" pusher hooks.

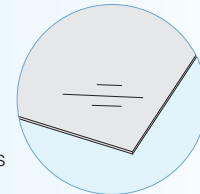

Shelf Works™ Expandable Wire Tray™ System

Shelf Works™ EWT™ Shelf Management System adjusts easily from 5" to 8" wide and is available in a range of lengths. EWT is well suited for almost any product size and package style from boxes and bags, to tubs, blister packs and clamshells.

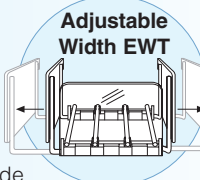

WonderBar® Wire Basket

Three inch deep baskets are available 6" and 12" wide and in 5 lengths from 9.6" to 17.5" to complement WonderBar EWT™.

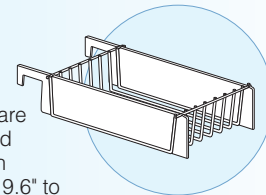

WonderBar® Square Cross Bar Tube

Standard-size, heavy-duty 1" Square Cross Bar Tube mounts with Universal Brackets (provided) to most gondola and uprights in coolers, freezers, dry goods areas, and on standard gondola center store. ColorPerm® powder coating resists the effects of harsh environments. Standard powder coat colors are White, Black, Beige and Silver. Available in 30", 36" and 48" lengths.

Display Hook System for WonderBar®

Saddle mount, heavy-duty 0.283" (1 gauge) diameter wire hooks are available in 12", 14" and 16" lengths and are capable of withstanding heavy loads and harsh environments including coolers and freezers. Standard powder coat colors are White, Black, Beige and Silver.

Clear Scan® AdjustaView® Label System

AdjustaView® Labeling option is available to run across the front of the display including both Display and Pusher Hook areas. AdjustaView® accepts economical plain-paper labels and can be angled at -15°, 0°, or +15° to vertical for optimal viewing. Available in 30", 36" and 48" lengths, and 30mm and 39mm label holder heights. AdjustaView® Arms are 0.283" wire available in 12", 14", and 16" lengths, as L-front left- and right-hand mount pairs or T-front center arms. Standard powder coat colors are White, Black, Beige and Silver.

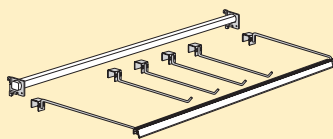
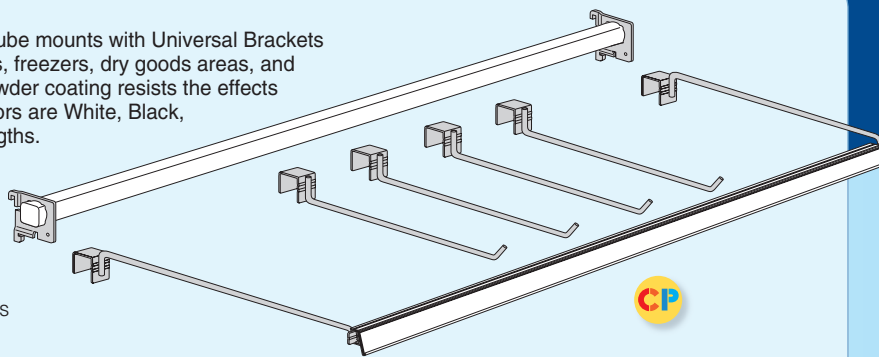

WonderBar® Kit – TRWB48KIT 1-U

- 1 – Square Bar WONDERBAR48BK
- 8 – Hooks WBRL14CPBK
- 1 – Label Holder Arm Set WBSCAN14 SET-BK
- 1 – Label Holder PPV-30-BK-1219

\$18¹¹
"As Low As"

Standard color for kit is Black with Black Label Holder, other colors available. Minimums may apply.

Pusher Hook System for WonderBar®

Saddle mount, heavy-duty 0.283" (1 gauge) wire hooks are available in 12", 14" and 16" lengths and are capable of withstanding heavy loads and harsh environments including coolers and freezers. Spring loaded pushers keep product forwarded, well faced and promote sales. Standard powder coat colors are White, Black, and Silver.

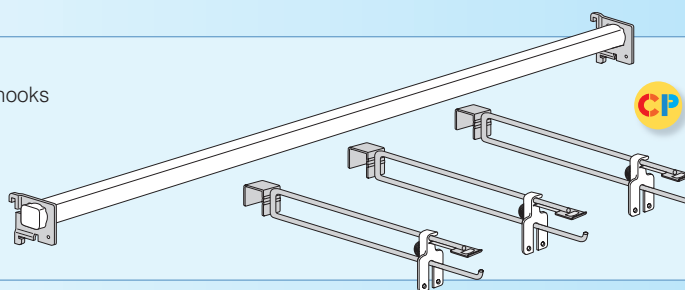

Shelf Works® Expandable Wire Tray™ System

Shelf Works® EWT™ eliminates the need for standard shelves, allows easy lane width adjustment from 5" to 8" wide and is well suited for almost any product size and package style from boxes and bags, to tubs, blister packs and clamshells. EWT™ lifts out for easy restocking and product rotation and is available in 5 lengths from 9.6" to 17.5". Optional accessories include Wire or Clear Plastic Front Product Stop, automatic, self-facing Spring Feed, and individual product lane Label Holder System. Standard powder coat colors are White, Black, Beige and Silver.

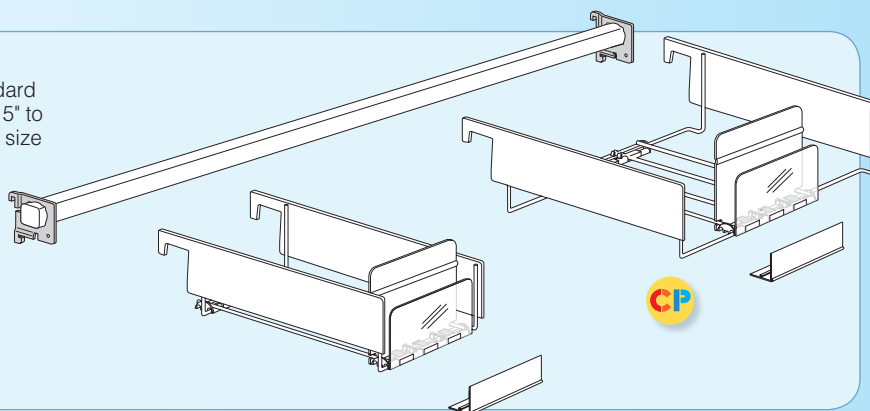

WonderBar® Wire Basket

Three inch deep baskets are available 6" and 12" wide and in 5 lengths from 9.6" to 17.5" to complement WonderBar EWT™. Optional 1 1/4" x 3" label holders. Wire Baskets are suitable for small, random or unusual shape items (samplers, single serve packs, etc), horizontal cylinder shapes (meats, cheeses, biscuits, cookie dough, etc), informal "dump bin" style presentations, and lift out for easy restocking. Standard powder coat colors are White, Black, Beige and Silver.

